



Hi-tech system
LIGHT FULL 2836ST



Light Full 2836ST è il profilo ideale per tende a strappo multicanali sia a Onda (su un canale solo) che arricciate su tre canali. Più compatto rispetto al classico Full con egual numero di vie, il Light Full si adatta a spazi ristretti senza però rinunciare alla bellezza e all'eleganza di diversi strati di tessuto che si completano.

Dritto o arcato, qualsiasi sia l'esigenza richiesta, Light Full è pensato per soddisfarla. Dall'arredamento degli alberghi più lussuosi ai moderni interni di case, Light Full permette di creare design sia minimal che estremamente ricchi.



Light Full 2836ST is the ideal profile for manual multi-channel curtains. Suitable both for "wave" curtains (on one channel only) and for standard draped curtains on all the three channels. More compact than the classic Full but with the same number of channels, it can be easily installed in tight spaces without giving up the elegance and beauty of multiple curtains.

Light Full can be made straight or arched and is suitable for both luxury hotels or modern houses since it allows to create both minimal and very rich design.



Light Full 2836ST est le profil idéal pour les rideaux multicanaux actionnés manuellement à la fois sur ondes (sur un canal) et drapés sur trois canaux. Plus compact que le classique Full avec un nombre égal de rues, le Light Full s'adapte à des espaces confinés sans sacrifier la beauté et l'élégance de plusieurs couches de tissu qui se complètent.

Droit ou arqué, quel que soit le besoin requis, Light Full est conçu pour le satisfaire. Du décor d'hôtel le plus luxueux aux intérieurs modernes des maisons, Light Full vous permet de créer des designs à la fois minimalistes et extrêmement riches.

SISTEMA PIATTO PER TENDE ARRICCIATE A TRE CANALI (A STRAPPO)

Three-way flat system for draped curtains (hand control)

Système plat pour rideaux drapés sur trois canaux (manuel)

■ ■ Utilizzo

- Sistema per tende arricciate a tre canali
- Azionamento a strappo
- Indicato per tendaggi di larghezza massima cm. 600
- Il sistema è adatto per installazioni a soffitto o a parete
- Lo scorrimento è garantito da canali siliconati e scivoli autolubrificanti

■ ■ Use

- Three-way flat system for draped curtains
- Hand operation
- Suitable for curtains up to cm 600 width
- It can be fixed both at the ceiling or at the wall
- Sliding is guaranteed by self-lubricating sliders in polyethylene HDPE.

■ ■ Utilisations

- Système de rideau drapé à trois canaux
- Actionnement manuel
- Convient pour rideaux de largeur maximale cm. 600
- Le système convient pour installations au plafond et au mur
- Le glissement est garanti par des canaux en silicone et des toboggans autolubrifiants

■ ■ Caratteristiche tecniche

- Profilo in lega d'alluminio estrusa 6060 T5 UNI EN 755-9
- Dimensioni mm. 11x84
- Canale di scorrimento mm. 6
- Raggio di curvatura per soffitti arcati: r minimo 100 cm.
- Colori disponibili:
 - ◆ verniciatura a polvere a base di resine poliesteri omologata a marchio QUALICOAT BIANCO RAL 9010
- Tappo terminale in acetalica antiurto
- Accessori in acetalica autolubrificante
- Optional: Raggio di curvatura per soffitti arcati: minimo r 100cm
- Optional: Scorrevole in acetalica con rotelle autolubrificanti
- Optional: Guidatiro in acetalica con rotelle autolubrificanti e sormonto in acciaio da cm. 8

■ ■ Technical features

- Profile made of extruded aluminium alloy 6060 T5 UNI EN 755-9
- Size mm. 11x84
- Canale di scorrimento mm. 6
- Sliding channel mm. 6
- Available colours:
 - ◆ Powder coating with polyester resins, homologated QUALICOAT white RAL 9010
- Endcap in acetalic shockproof resin
- Accessories in self-lubricating acetal resin
- Optional: Bending radius: minimum 100cm
- Optional: Sliders in acetalic resin with self-lubricating rollers
- Optional: Cord-slide in acetalic resin with self-lubricating rollers and 8cm steel overlap

■ ■ Spécifications

- Profil en alliage d'aluminium extrudé 6060 T5 UNI EN 755-9
- Taille mm. 11x84 bien
- Canal de glissement mm. 6
- Rayon de distorsion pour les plafonds arqués : minimum r cm. 100
- Couleurs disponibles:
 - ◆ Poudre PAINT à base de résines de polyester approuvée par la marque QUALICOAT WHITE RAL 9010
- Capuchon terminal en acétalica de choc
- Accessoires acétaliques autolubrifiants
- Facultatif : rayon de distorsion pour les plafonds arqués : minimum r cm. 100
- Facultatif : Glissement en acétalica avec roues autolubrificantes
- Facultatif : Guide acétalique avec roues autolubrifiantes et affleurement en acier par cm. 8

Colori

colours / couleurs



101 Bianco / White / Blanc

Misure profili

profiles sizes / mesures des profils

Profilo LIGHT FULL

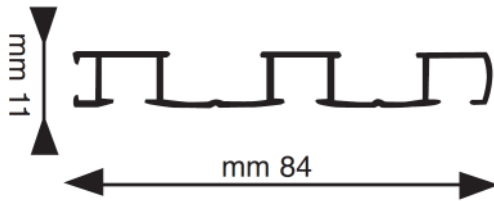

Soluzioni

solutions / solutions

D

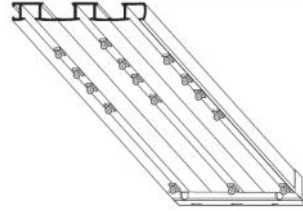

P

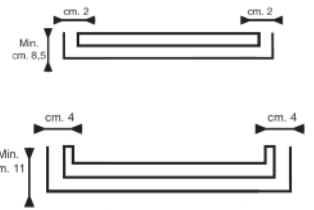
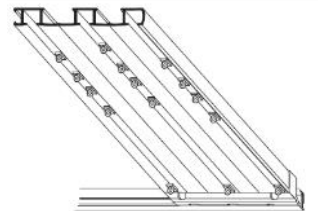

CN=A

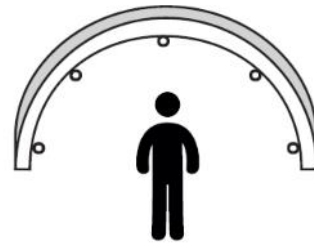

Scivoli e scorrevoli

sliders / glisseurs

Art.3141



Art. 3142

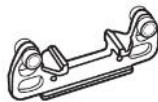

Art. 3142+2719



Art. 3144



Schema aperture

Opening examples / exemple d'ouverture

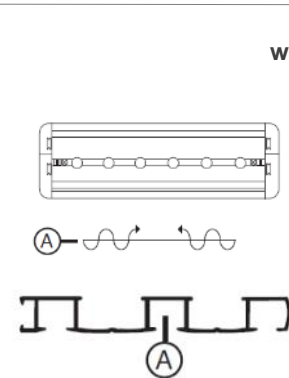
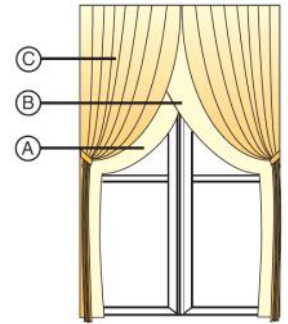
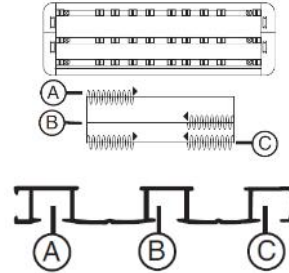
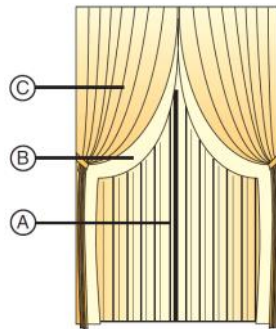
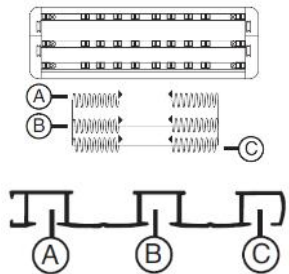
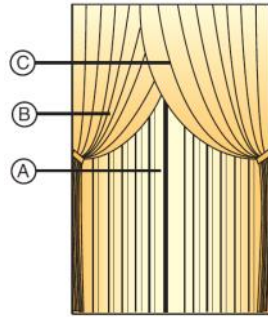
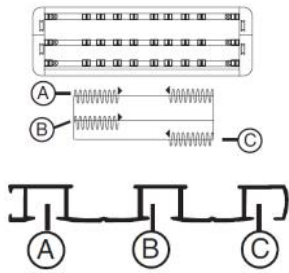

ONDA
wave / onde

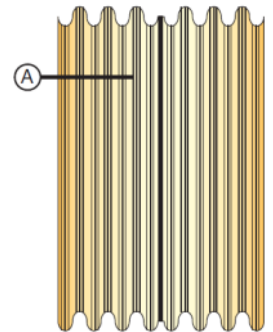

Installazioni fixing / installations

Installazione a soffitto / ceiling fixing / au plafond

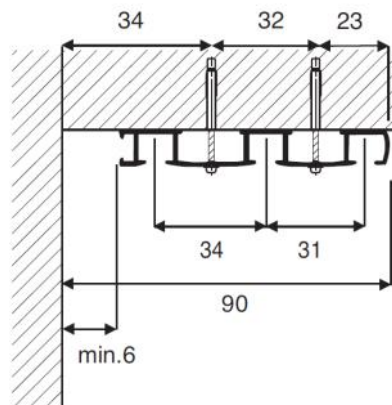

Art. 2784

Installazione a parete / wall fixing / au mur

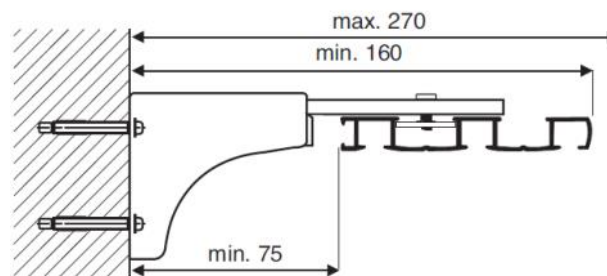

Art.2713+2714+2785

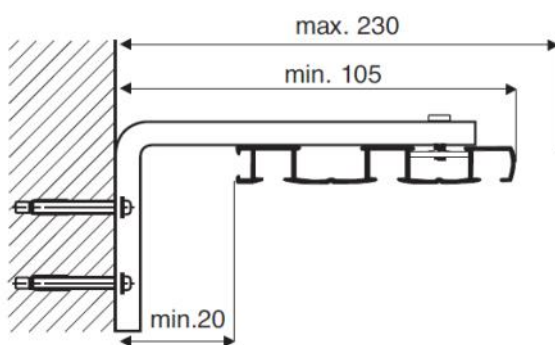

Art. 2721+2725/15+2785

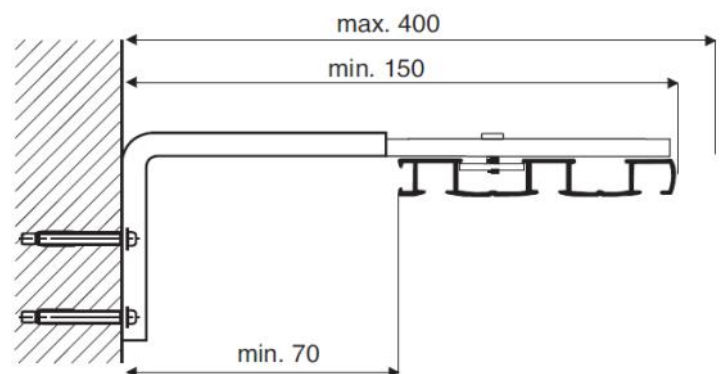

Art.2721+2714+2785

Esploso

exploded view / vue éclatée

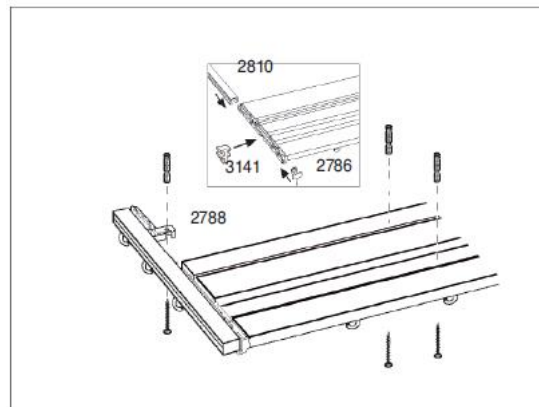
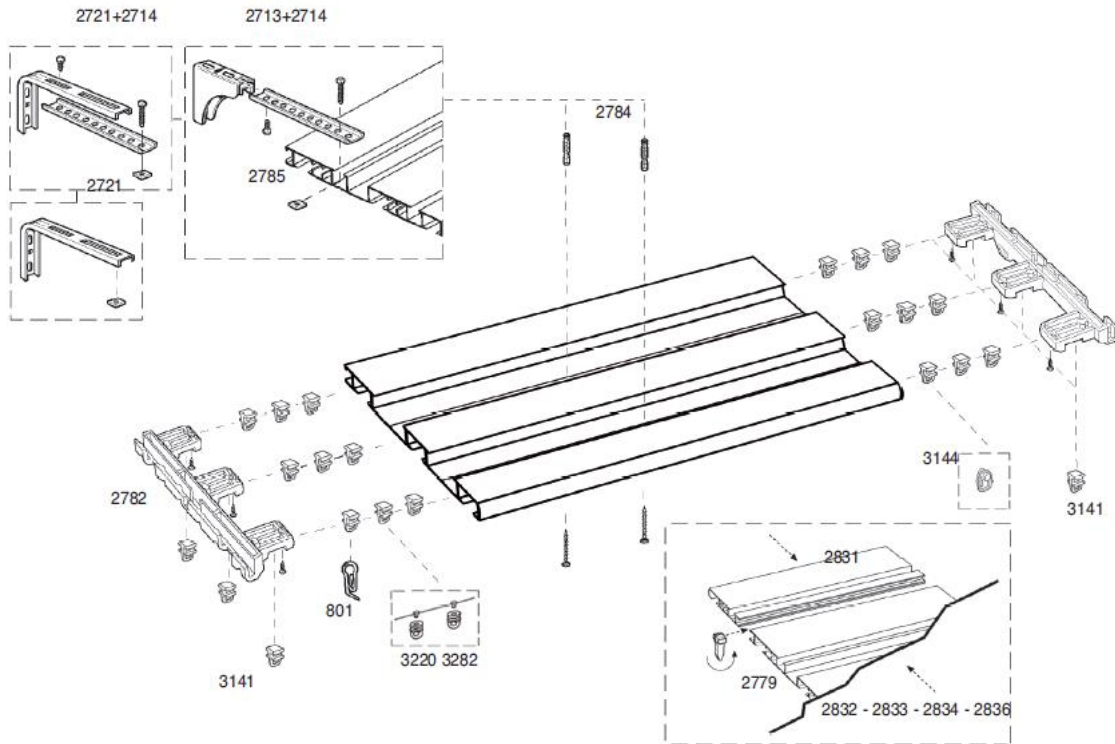



TENDE INTERNE ED ESTERNE

Rilox Italia Srl - Cap. Soc. €150.000,00 I./V.

Via Cascina Borniola, 15/A - 10036 Settimo Torinese (TO) - ITALY

Reg. Imprese Torino - C.F. - P. IVA - 10634150014 - R.E.A. 1149982

Ufficio Registro TORINO 2 - PEC: riloxitalia@pec.it

Tel:(+39) 011 262 5473 - Fax: (+39) 011 22 22 250

www.riloxitalia.it



@rilox.italia



#riloxitalia