

Hi-tech system
FULL 2832C



Sistema piatto per tende aracciate a due canali.

Le tende aracciate possono essere realizzate in qualsiasi tipo di tessuto, non vi sono limitazioni né di peso né di tipologia, pertanto le possibilità d'arredo e creative risultano essere illimitate.



Two-way flat system for draped curtains

Draped curtains can be realized with any type of fabric, no weight or type limit, decoration possibilities are therefore unlimited.



Système plat pour rideaux enroulés à deux canaux avec cantonnière et décrocheurs latéraux.

Les rideaux enroulés peuvent être faits dans n'importe quel type de tissu, il n'y a aucune restriction de poids ou de type, ainsi les possibilités d'ameublement et de création sont illimitées.

SISTEMA PIATTO PER TENDE ARRICCIATE A DUE CANALI

Two-way flat system for draped curtains

Système plat pour rideaux drapés sur deux canaux

Utilizzo

- Sistema per tende arricciate a due canali
- Azionamento con corde o a strappo
- Indicato per tendaggi di larghezza massima cm. 600
- Apertura tende su canali indipendenti: centrale, laterale e simmetrica; oppure doppia tenda a incrocio (totale o parziale) con comando unico
- Il sistema è indicato per installazioni a soffitto o a parete
- Il sistema di scorrimento delle corde è situato in canali indipendenti e paralleli
- Lo scorrimento è garantito da scorrevoli con rotelle autolubrificanti

Use

- Two-way flat system for draped curtains
- Hand or cord operation
- Suitable for curtains up to cm 600 width
- Curtains opening on independent channels: central, lateral and asymmetric; or double crossed curtains (with total or partial overlap) with unique control
- It can be fixed both at the ceiling or at the wall
- The cords slide in parallel independent channels
- Sliding is guaranteed by self-lubricating sliders in polyethylene HDPE.

Utilisations

- Système de rideau courbé à deux canaux
- Actionnement avec des cordes ou manuel
- Convient aux rideaux de largeur maximale cm. 600
- Ouverture sur les canaux indépendants : central, latéral et symétrique; ou store à double intersection (totale ou partielle) avec commande unique
- Le système convient pour installations au plafond et au mur
- Le système de glissement de chaîne est situé dans des canaux indépendants et parallèles
- La glissade est garantie en glissant avec des roues autolubrificante

Caratteristiche tecniche

- Profilo in lega d'alluminio estrusa 6060 T5 UNI EN 755-9
- Dimensioni mm. 11x84
- Canale di scorrimento mm. 6
- Colori disponibili:
 - ◆ verniciatura a polvere a base di resine poliesteri omologata a marchio QUALICOAT BIANCO RAL 9010
- Carrucole in acetalica antiurto con perni in acciaio
- Guidatiro in acetalica con rotelle autolubrificanti e sormonto in acciaio da cm. 8
- Accessori in acetalica autolubrificante

Technical features

- Profile made of extruded aluminium alloy 6060 T5 UNI EN 755-9
- Size mm. 11x84
- Sliding channel mm. 6
- Available colours:
 - ◆ Powder coating with polyester resins, homologated QUALICOAT white RAL 9010
- Pulleys in acetalic shockproof resin with steel pins
- Cord-slide in acetalic resin with self-lubricating rollers and 8cm steel overlap
- Accessories in self-lubricating acetal resin

Spécifications

- Profil en alliage d'aluminium extrudé 6060 T5 UNI EN 755-9
- Taille mm. 11x84 bien
- Canal de glissement mm. 6
- Couleurs disponibles:
 - ◆ Poudre PAINT à base de résines de polyester approuvée par la marque QUALICOAT WHITE RAL 9010
- Carrucies d'acétalc de choc avec des goupilles en acier
- Guide latéral avec roues auto-lubrifiantes et un affleurement en acier par cm. 8
- Accessoires acétaliques autolubrifiants

Colori

colours / couleurs

 101 Bianco / White / Blanc

Misure profili

profiles sizes / mesures des profils

Profilo FULL

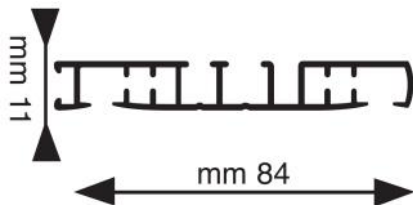

Schema aperture

Opening examples / exemple d'ouverture

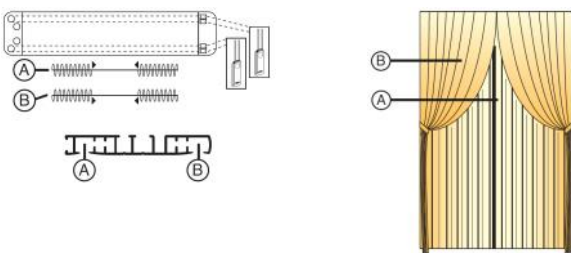
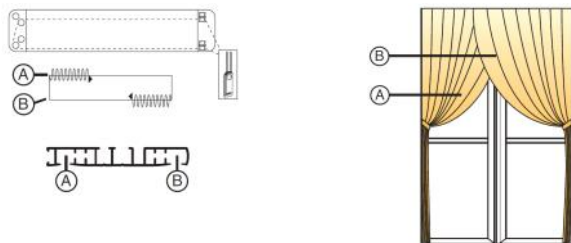
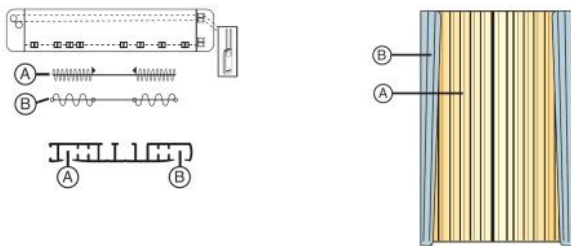

ONDA wave / onde

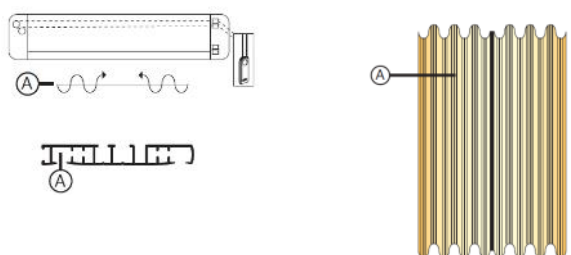

Soluzioni di utilizzo

Application solutions / Solutions d'emploi

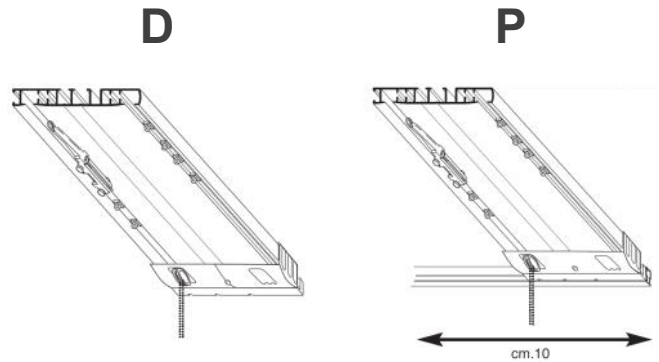

CN=A

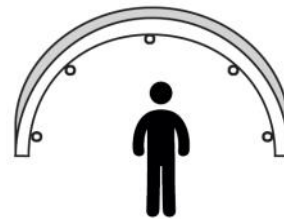

Portata

maximum load / gamme

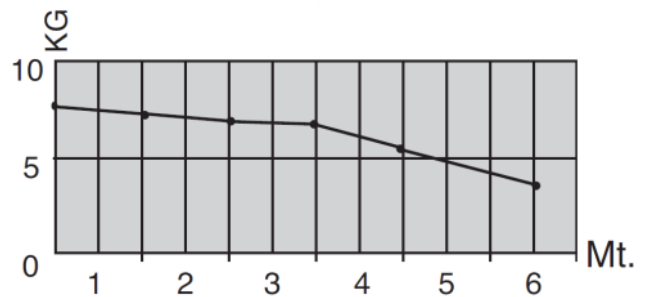

Scivoli e scorrevoli

sliders / glisseurs

Art.3144

Art. 2719- 3242



Installazioni fixing / installations

Installazione a soffitto / ceiling fixing / au plafond

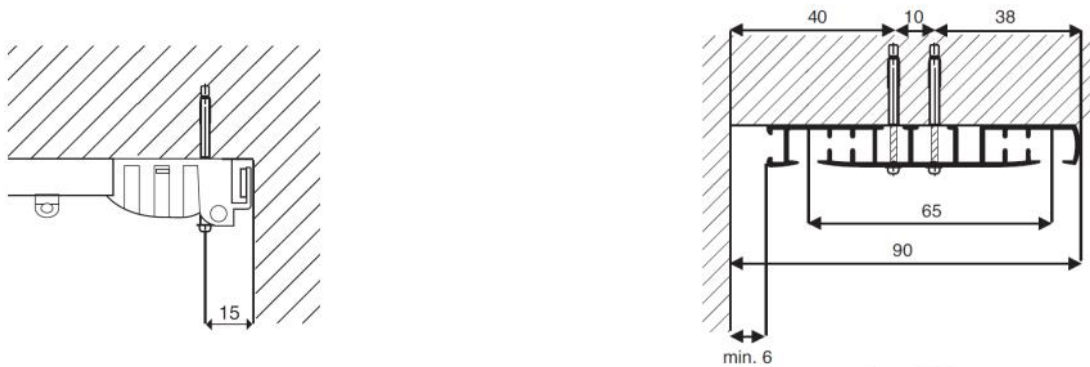

Art. 2784

Installazione a parete / wall fixing / au mur

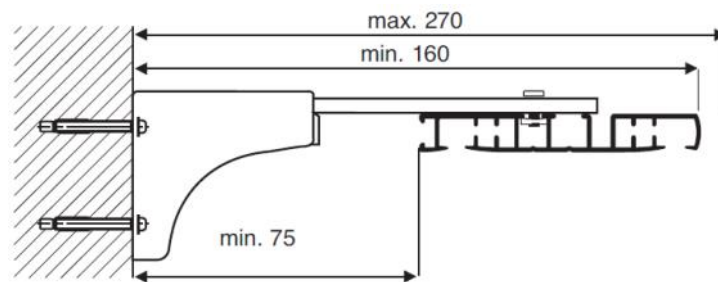

Art.2713+2714+2785

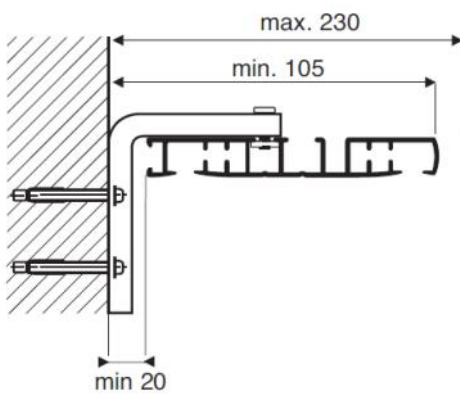

Art. 2721+2725/15+2785

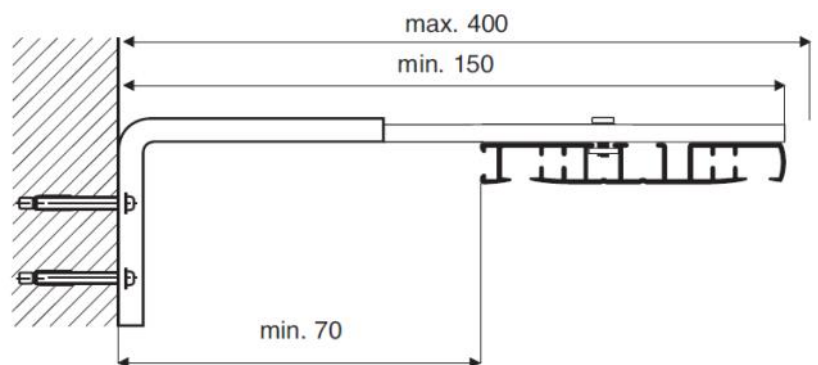

Art.2721+2714+2785

Esploso

exploded view / vue éclatée

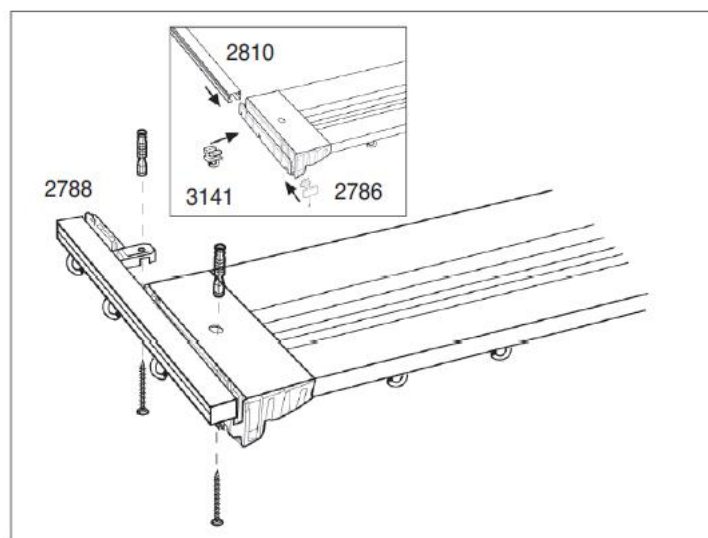
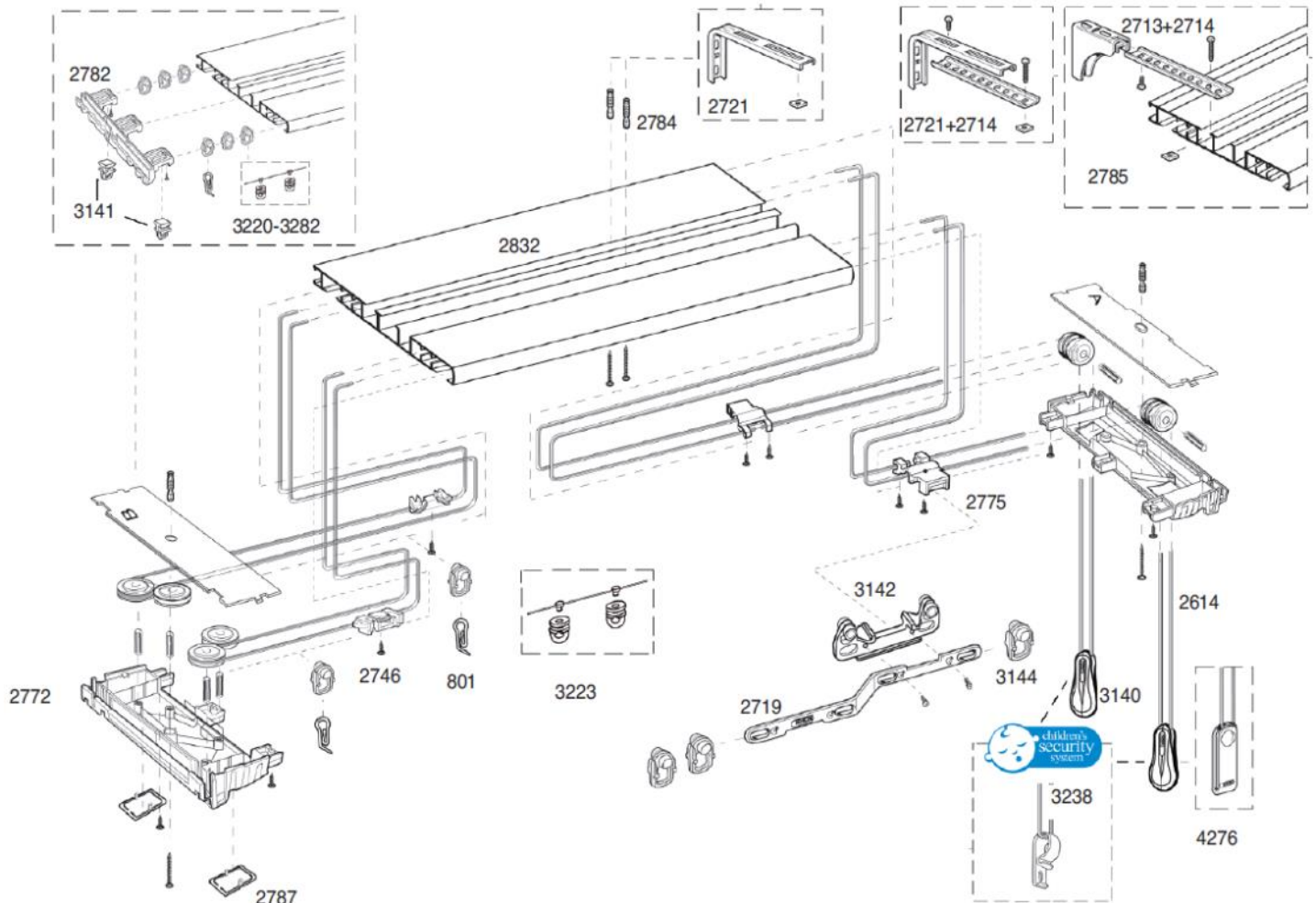



TENDE INTERNE ED ESTERNE

Rilox Italia Srl - Cap. Soc. €150.000,00 I./V.

Via Cascina Borniola, 15/A - 10036 Settimo Torinese (TO) - ITALY
Reg. Imprese Torino - C.F. - P. IVA - 10634150014 - R.E.A. 1149982
Ufficio Registro TORINO 2 - PEC: riloxitalia@pec.it
Tel:(+39) 011 262 5473 - Fax: (+39) 011 22 22 250

www.riloxitalia.it



@rilox.italia



#riloxitalia