



Hi-tech system
FULL 2831M



Sistema piatto per tende arricciate a un canale con mantovana e calate laterali.

Le tende arricciate possono essere realizzate in qualsiasi tipo di tessuto, non vi sono limitazioni né di peso né di tipologia, pertanto le possibilità d'arredo e creative risultano essere illimitate.



One-way flat system for draped curtains with valance and side curtains.

Draped curtains can be realized with any type of fabric, no weight or type limit, decoration possibilities are therefore unlimited.



Système plat pour rideaux enroulés à un canal avec can-tonnière et décrocheurs latéraux.

Les rideaux enroulés peuvent être faits dans n'importe quel type de tissu, il n'y a aucune restriction de poids ou de type, ainsi les possibilités d'ameublement et de création sont illi-mitées.

SISTEMA PIATTO PER TENDE ARRICCIATE A UN CANALE CON MANTOVANA E CALATE**One-way flat system for draped curtains with valance and side curtains****Système plat pour rideaux drapés sur un canal avec cantonnière et descente****Utilizzo**

- Sistema per tende arricciate a un canale con mantovane e calate laterali
- Azionamento a corde e a strappo
- Indicato per tendaggi di larghezza massima cm. 600
- Apertura tenda centrale, laterale, multipla o asimmetrica
- Il sistema è indicato per installazioni a soffitto e a parete
- Il sistema di scorrimento delle corde d'azionamento in canali indipendenti permette di realizzare centine ad ampio raggio per soffitti arcati
- Lo scorrimento è garantito da scorrevoli con rotelle autolubrificanti

Use

- One-way flat system for draped curtains with valance and side curtains
- Hand or cord operation
- Suitable for curtains up to cm 600 width
- Opening can be: central, lateral, multiple or asymmetrical
- It can be fixed both at the ceiling or at the wall
- The cords sliding into independent channels allow to realize big radius curves for arched ceilings
- Sliding is guaranteed by self-lubricating sliders in polyethylene HDPE.

Utilisations

- Système pour rideaux drapés à un canal
- Entraînement par cordes et manuel
- Convient pour rideaux de largeur maximale cm. 600
- Ouverture centrale, latérale, multiple ou asymétrique du rideau d'aliét
- Le système convient pour installation au plafond et au mur
- Le système de glissement de chaîne d'entraînement dans les canaux indépendants permet de faire des centinations à large portée pour les plafonds arqués
- La glissade est garantie en glissant avec des roues autolubrificantes

Caratteristiche tecniche

- Profilo in lega d'alluminio estrusa 6060 T5 UNI EN 755-9
- Dimensioni mm. 11x40
- Canale di scorrimento mm. 6
- Raggio di curvatura: minimo r = cm. 100
- Colori disponibili:
 - ◆ verniciatura a polvere a base di resine poliesteri omologata a marchio QUALICOAT BIANCO RAL 9010
- Carrucole in acetalica antiurto con perni in acciaio
- Guidatiro in acetalica con rotelle autolubrificanti e sormonto in acciaio da cm. 8
- Accessori in acetalica autolubrificante
- Portatelo in lega d'alluminio estrusa 6060 T5 UNI EN 755-9 con Velcro adesivo (bloccato su tutta la lunghezza)

Technical features

- Profile made of extruded aluminium alloy 6060 T5 UNI EN 755-9
- Size mm. 11x40
- Sliding channel mm. 6
- Bending radius: minimum 100cm
- Available colours:
 - ◆ Powder coating with polyester resins, homologated QUALICOAT white RAL 9010
- Pulleys in acetalic resin with steel pins
- Cord-slide in acetalic resin with self-lubricating rollers and 8cm steel overlap
- Accessories in self-lubricating acetal resin
- Panel holder made of extruded aluminium alloy T5 UNI EN 755-9 with adhesive Velcro (fixed all the length through)

Spécifications

- Profil en alliage d'aluminium extrudé 6060 T5 UNI EN 755-9
- Taille mm. 11x40
- Canal de glissement mm. 6
- Rayon de distorsion : minimum r plus cm. 100
- Couleurs disponibles:
 - ◆ Poudre PAINT à base de résines de polyester approuvée par la marque QUALICOAT WHITE RAL 9010
- Carrucies d'acétalc de choc avec des goupilles en acier
- Guide latéral avec roues auto-lubrifiantes et un affleurement en acier par cm. 8
- Accessoires acétaliques autolubrificants

Colori

colours / couleurs



101 Bianco / White / Blanc

Misure profili

profiles sizes / mesures des profils

Profilo FULL

Portatelo velcrato

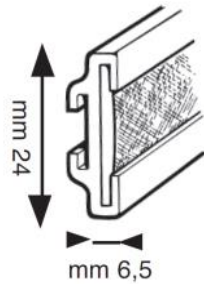

Portata

maximum load / gamme

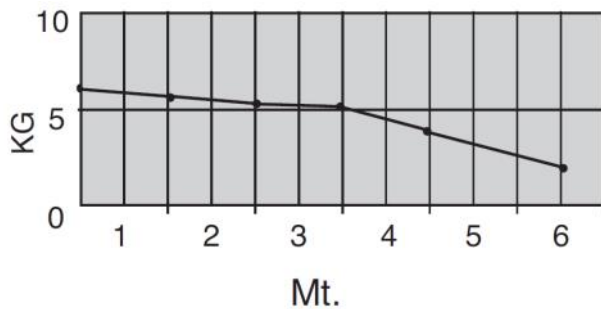

Scivoli e scorrevoli

sliders / glisseurs

Art.3144



Art. 2719- 3242



Soluzioni di utilizzo

Application solutions / Solutions d'emploi

D

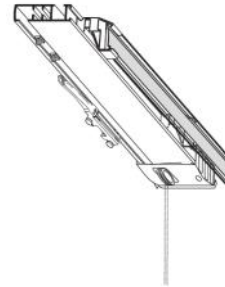

P

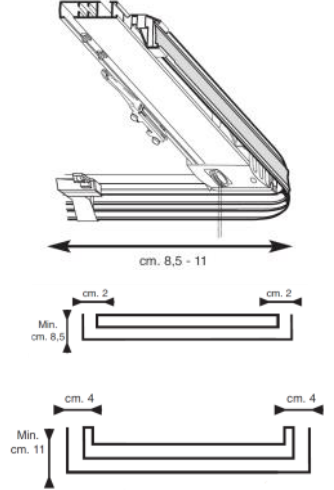

CN=A

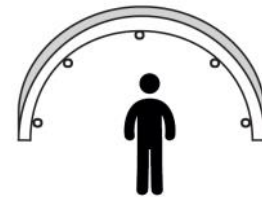

Schema aperture

Opening examples / exemple d'ouverture

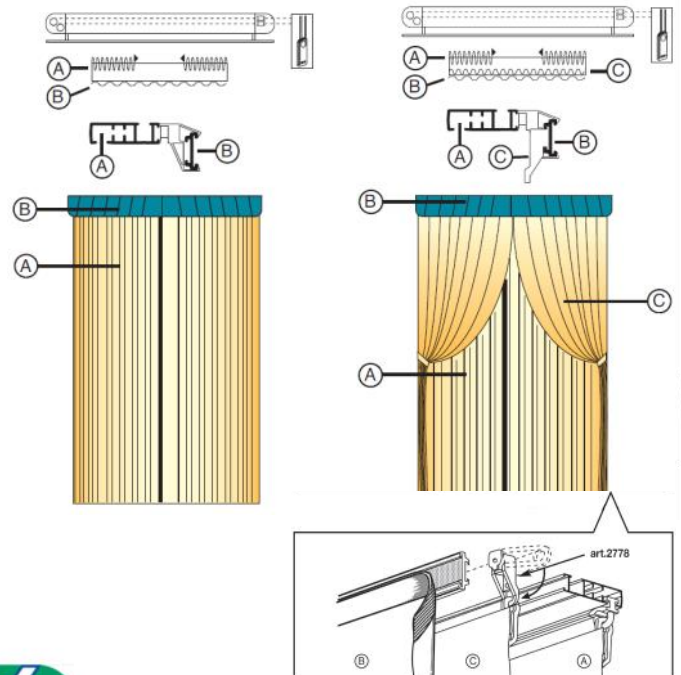

Installazioni fixing / installations

Installazione a soffitto / ceiling fixing / au plafond

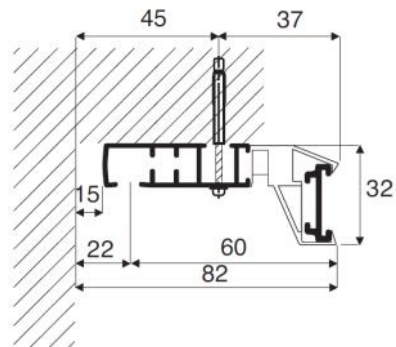

Art. 2784

Installazione a parete / wall fixing / au mur

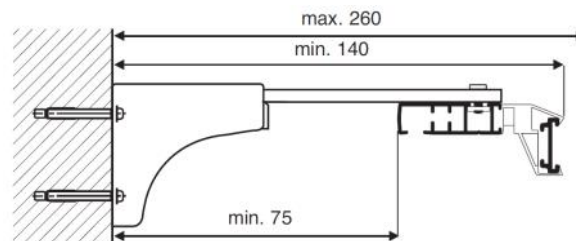

Art.2713+2714+2785

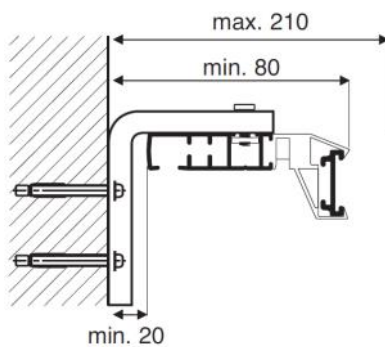

Art. 2721+2725/15+2785

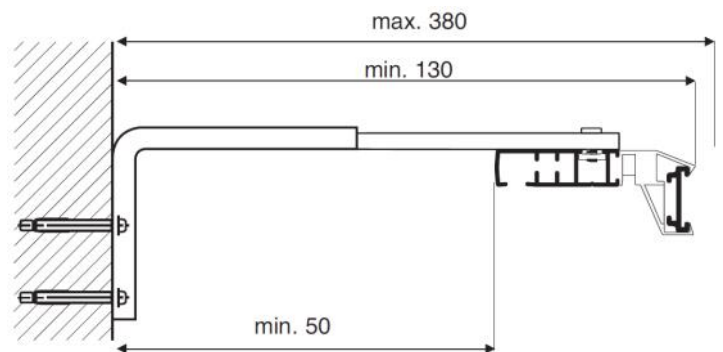

Art.2721+2714+2785

Esploso

exploded view / vue éclatée

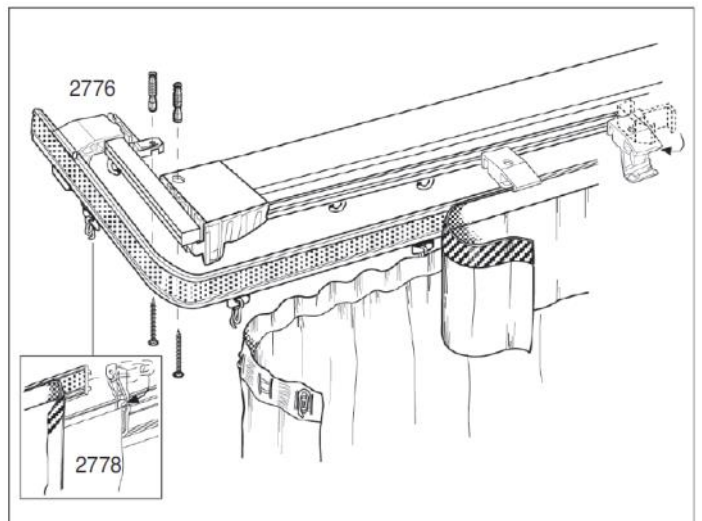
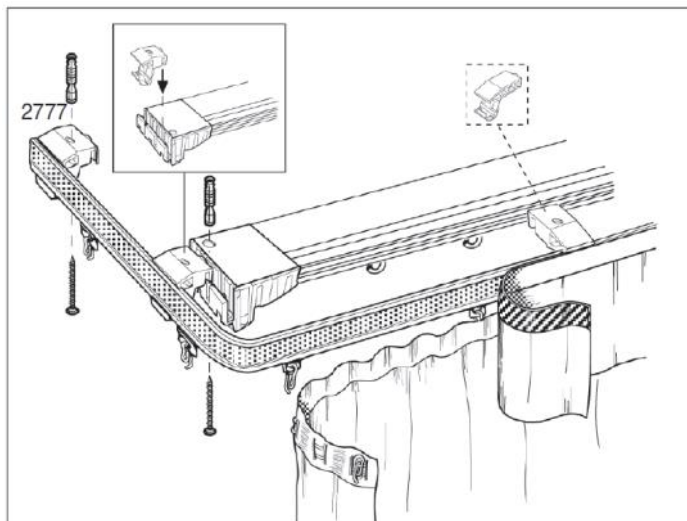
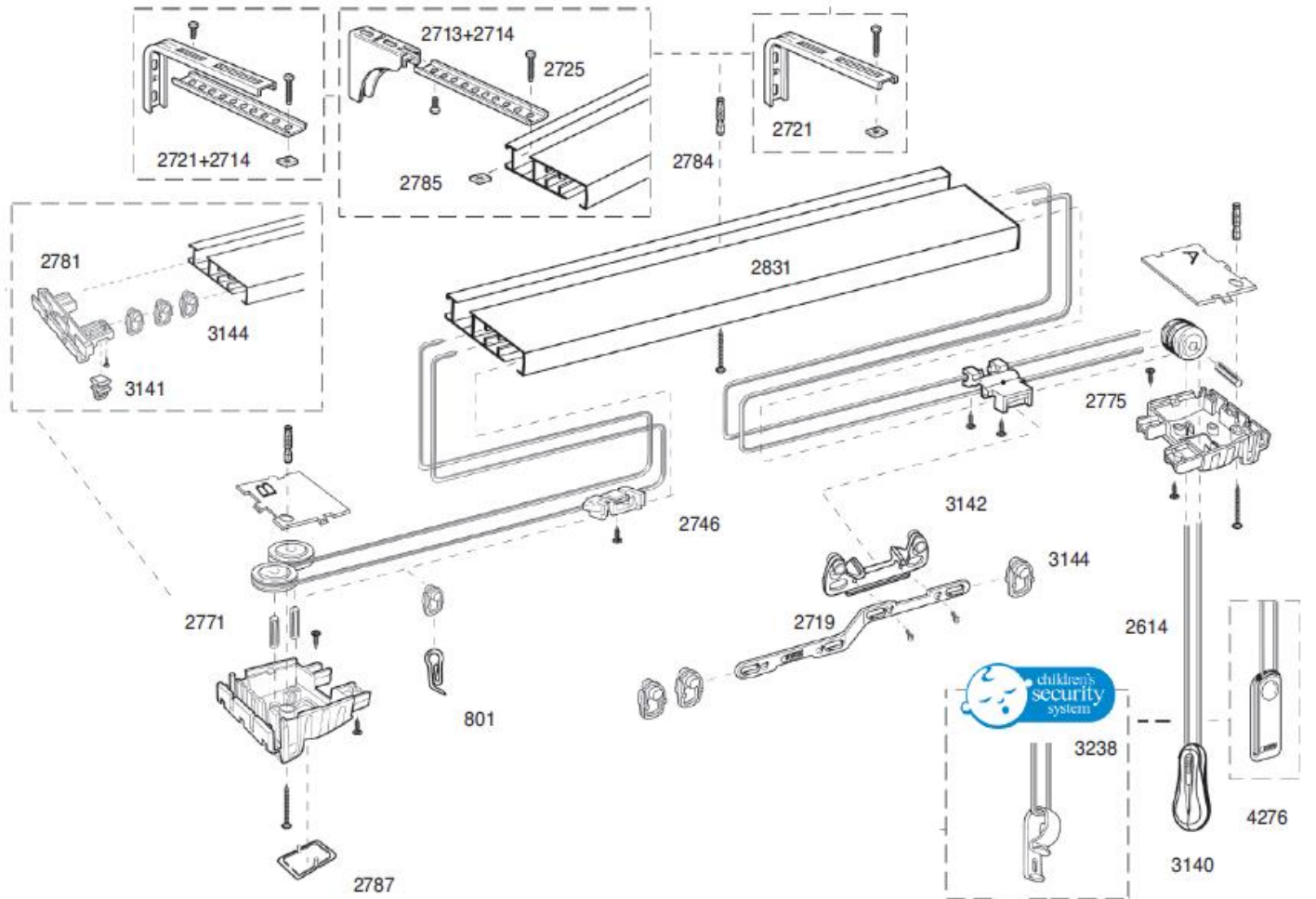



TENDE INTERNE ED ESTERNE

Rilox Italia Srl - Cap. Soc. €150.000,00 I./V.

Via Cascina Borniola, 15/A - 10036 Settimo Torinese (TO) - ITALY
Reg. Imprese Torino - C.F. - P. IVA - 10634150014 - R.E.A. 1149982
Ufficio Registro TORINO 2 - PEC: riloxitalia@pec.it
Tel:(+39) 011 262 5473 - Fax: (+39) 011 22 22 250

www.riloxitalia.it



@rilox.italia



#riloxitalia