



*GoGarden*

*Hi-tech system*

**3083C10**



Go-Garden 3083C10 è il sistema con comando ad arganello studiato per lucernai, giardini d'inverno, vetrate inclinate o orizzontali, curvate o centinate. Progettato per ambienti interni, è stato studiato per sorreggere schermature fino a 10 kg grazie alla presenza di guide laterali parallele.

Per adattarsi al meglio a più tipi di arredamento, è possibile scegliere tra una versione tesa (indicato per ambienti più minimal-chic) e una versione drappeggiata per ambienti più classici e senza tempo.

È possibile montare Go-Garden a qualsiasi inclinazione e altezza, così come scegliere un'apertura centrale o laterale. Inoltre, l'asta di comando è comodamente sganciabile: in caso di presenza di bambini, riporlo in un luogo sicuro sarà facile e veloce.



Go-Garden 3083C10 is a winch-operated system designed for skylights, wintergardens, sloped and horizontal windows, both straight and bent. Suitable for indoor, thanks to its parallel side guides it can hold up to 10kg fabrics.

To adapt to any environment, two models are available: one with straight fabric (suitable for minimal-chic environments) and the other with draped fabric, for a classical and timeless style.

Go-Garden can be installed at any height and with any inclination; curtains can have a lateral or a central opening.

Finally, the control bar is detachable, so that it can be stored away for child safety.



Le Go-Garden est un système à cabestan étudié pour la couverture de lucarnes, jardins d'hiver, verrières inclinées ou horizontales, courbées ou cintrées. Projeté pour l'intérieur, ce système peut soutenir un poids du tissu jusqu'à 10kg, grâce à ses guides latérales parallèles.

Pour mieux s'adapter à n'importe quel environnement, deux modèles sont disponibles : un avec toile étendue (adapté pour environnements minimal-chic) et l'autre avec toile drapée, pour environnements plus classiques et intemporel.

Le Go-Garden peut être installé à toutes les hauteurs et inclinaisons, et il peut prévoir une ouverture centrale ou latérale.

En plus, la tige de commande est détachable, donc elle peut être facilement stockée en lieu sûr en cas de présence d'un enfant.

## SISTEMA AD ARGANELLO PER GIARDINI D'INVERNO FINO A 10kg

### Winch-operated system for winter gardens up to 10kg

### Système à cabestan pour jardins d'hiver jusqu'à 10kg

#### Utilizzo

- Sistema ad arganello adatto per lucernai, vetrate orizzontali, pendenti, tetti di atrium e giardini d'inverno
- Il sistema è studiato per la copertura di superfici con lati paralleli
- Aperture laterali o centrali
- Asta di comando snodata con aggancio e sgancio rapido
- Adatto per pendenze fino a 90°
- Adatto per curve e centine ad ampio raggio

#### Use

- System with chain operation suitable for skylights, horizontal, leaning and curved windows, atrium's ceilings and winter gardens
- This system was designed to cover surfaces with parallel sides
- Central or lateral opening
- Articulated control bar with quick-locking and -release.
- Suitable for slopes up to 90°
- Suitable for bends and big radius curved

#### Utilisations

- Système à cabestan approprié pour puits de lumière, vitraux horizontaux, pendentifs, toits d'atrium et jardins d'hiver
- Le système est conçu pour couvrir les surfaces avec des côtés parallèles
- Ouvertures lateral ou centrales
- Tige de commande articulée avec dispositif d'accrochage et décrochage rapide.
- Adapté pour inclinaisons jusqu'à 90°
- Adapté pour courbes et cintres

#### Caratteristiche tecniche

- Profilo, alberino di comando e carter di copertura in lega d'alluminio estrusa 6060 T5 UNI EN 755-9
- Dimensioni: profilo mm. 22x31 / Carter mm70x70
- Tondini in alluminio art.3133 diametro mm.12
- Portata massima tessuto 10 kg
- Dimensioni massime L=200 H=600
- Colori disponibili:
  - verniciatura a polvere a base di resine poliesteri omologata a marchio QUALICOAT BIANCO RAL 9010
- Carrucole per guida nastro con base in acciaio e ruote in acetale su perni in acciaio
- Nastro di movimentazione mm. 10
- Accessori in acetale autolubrificante
- Arganello di comando rapporto 2:1

#### Technical features

- Profile, rods and covering top made of extruded aluminium alloy 6060 T5 UNI EN 755-9
- Size: Profile mm 22x31 / Covering top mm 70x70
- 12 mm rods - art. 3133
- Fabric's maximum weight 10 kg
- Maximum size L=200 H=600
- Available colours:
  - Powder coating with polyester resins, homologated QUALICOAT white RAL 9010
- Steel pulleys for tape-guide with acetal resin roller on steel pins
- Drive-tape mm. 10
- Accessories in self-lubricating acetal resin
- Winch ration 2:1

#### Spécifications

- Profil, tiges et couverture en alliage d'aluminium extrudé 6060 T5 UNI EN 755-9
- Taille: profil 22x31 mm / couverture 70x70 mm
- Tige en aluminium art.3133 mm.12
- Gamme maximale stoff 10 kg
- Taille maximale L-200 H-600
- Couleurs disponibles:
  - Poudre PAINT à base de résines de polyester approuvée par la marque QUALICOAT WHITE RAL 9010
- Chariots de ruban adhésif avec base en acier et roues en acétalique sur des goupilles en acier
- Manipulation du ruban adhésif mm. 10
- Accessoires acétaliques autolubrifiants
- Cabestan de commande rapport 2:1

## Colori

colours / couleurs

 101 Bianco / White / Blanc

## Misure profili

profiles sizes / mesures des profils

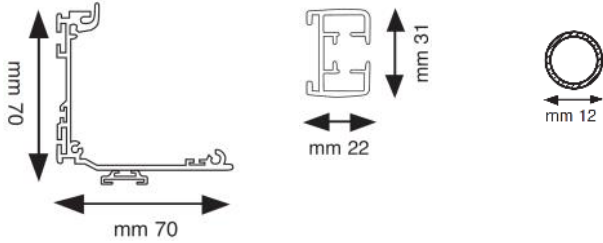

## Portata

maximum load / gamme

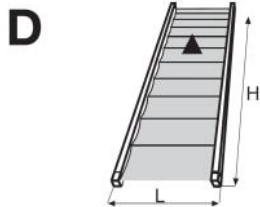

Max Kg.10

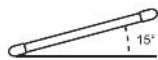

$> \text{Ø} \text{ e } < 15^\circ$

Max Kg.8

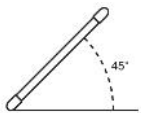

$> 15^\circ \text{ e } < 45^\circ$

Max Kg.4

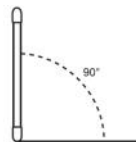

$> 45^\circ \text{ e } < 90^\circ$

Max Kg.4

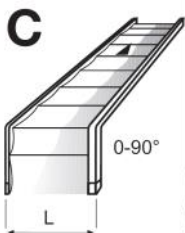

R. - 30 cm min.



Max Kg.3

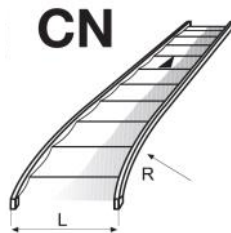

R. 100 cm min.



Max Kg.3

## Scivoli

sliders / glisseurs

Art.3130

Per telo dritto



Art.3130 con fermo catena

Per telo drappeggiato

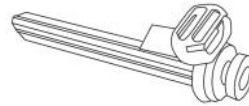

## Aperture e comandi

Openings and controls / ouvertures et actionnement

Aperture laterali / lateral opening / Ouvertures lateral art.3129

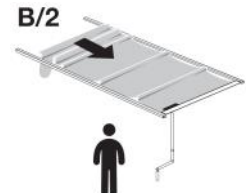
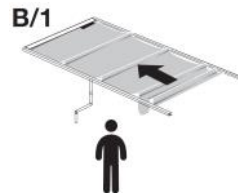
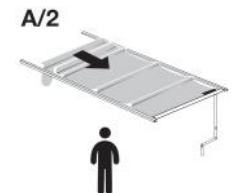

Aperture centrali / central opening / Ouvertures centrales art.3131

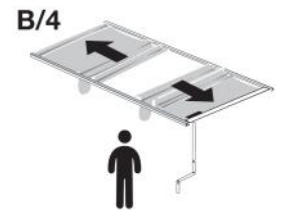
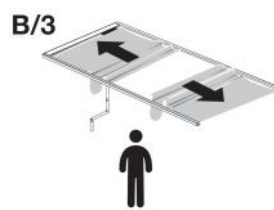
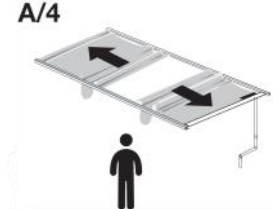
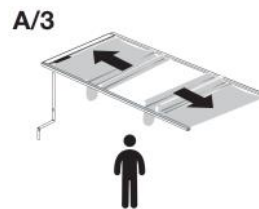

## Installazioni fixing / installations

### Installazione a parete / wall fixing / au mur

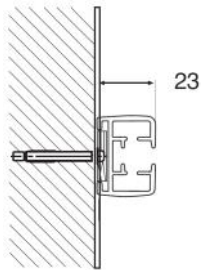

Art.3117

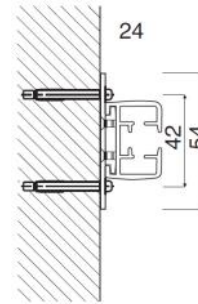

Art.3119

### Installazione a soffitto / ceiling fixing / au plafond

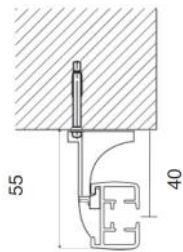

Art.3118

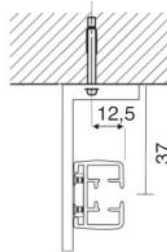

Art.3136

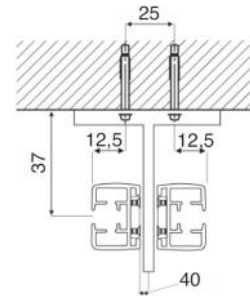

Art.3137

### In aggiunta per apertura centrale / Additional for central opening / En plus pour ouvertures centrales

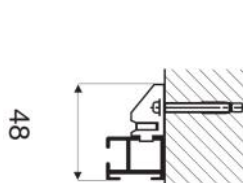

Art.2711

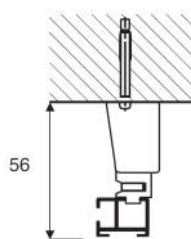

Art.2721+2711

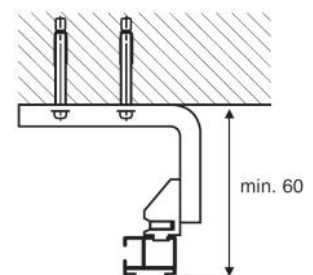

Art.2721+2723+2711

## Esploso

exploded view / vue éclatée

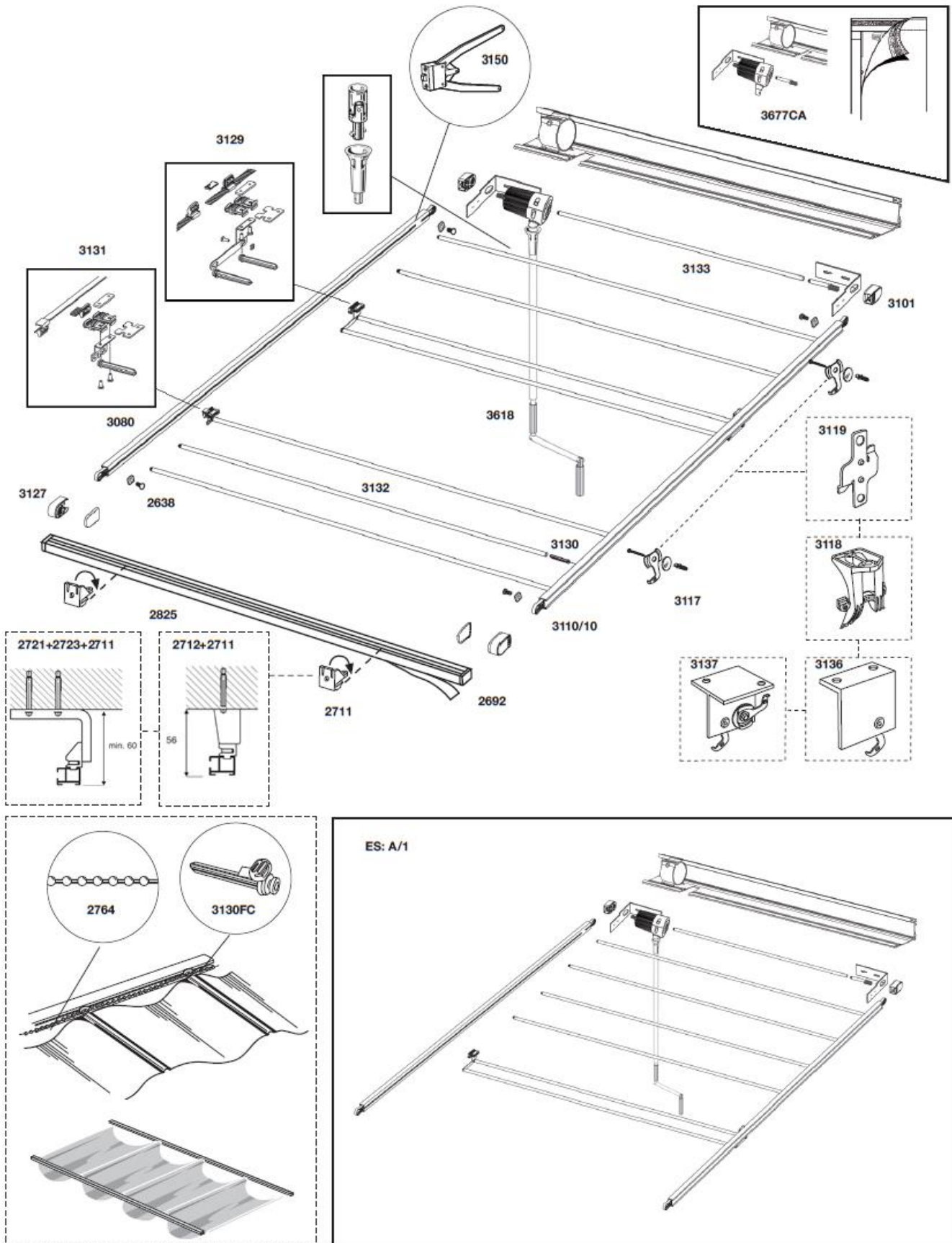



TENDE INTERNE ED ESTERNE

**Rilox Italia Srl** - Cap. Soc. €150.000,00 I./V.

Via Cascina Borniola, 15/A - 10036 Settimo Torinese (TO) - ITALY  
Reg. Imprese Torino - C.F. - P. IVA - 10634150014 - R.E.A. 1149982  
Ufficio Registro TORINO 2 - PEC: riloxitalia@pec.it  
Tel:(+39) 011 262 5473 - Fax: (+39) 011 22 22 250

[www.riloxitalia.it](http://www.riloxitalia.it)



@rilox.italia



#riloxitalia