



*Hi-tech system*  
**EVER 2810**



Sistema per tende aracciate medie e leggere.

Le tende aracciate o con le pieghe sono le più diffuse perché adatte a tutti i contesti: classico, moderno, country o etnico.

L'importante è scegliere i tessuti e i colori migliori per la propria casa, uniti agli accessori, al sostegno e all'aracciatatura più adatti al proprio stile di arredamento.

La caratteristica di questo sistema è la dimensione ridotta che gli consente di essere posto sotto assi o cornici.

Lo scorrimento è garantito da scivoli autolubrificanti in HDPE

Il sistema è progettato per installazioni sia a soffitto sia a parete.



System for light or middle draped curtains. Draped or pleated curtains are the most popular because they are suitable for any context: classic, modern, country or ethnic. What matters is that you choose fabrics and colours, together with accessories and curtain systems, the most appropriate to your home

The main feature of this system is the small size, that allows it to be placed also under wooden boards or valances

Sliding is guaranteed by the self-lubricating HDPE sliders.

The system is designed for ceiling or wall fixing.



Système pour rideaux courbés moyens et légers.

Les rideaux enroulés ou avec des plis sont les plus répandus parce qu'ils conviennent à tous les contextes : classique, moderne, pays ou ethnique. La chose importante est de choisir les meilleurs tissus et couleurs pour votre maison, combiné avec des accessoires, le soutien et le curling le mieux adapté à votre style d'aménagement.

La caractéristique de ce système est la petite taille qui lui permet d'être placé sous des haches ou des cadres.

Le glissement est garanti par des toboggans autolubrifiants dans le HDPE

Le système est conçu pour les installations au plafond et au mur.

# SISTEMA PER TENDE ARRICCIATE MEDIE

## System for middle draped curtains

## Mécanisme pour rideaux froncés

### Utilizzo

- Sistema per tende arricciate medie e leggere
- Azionamento a strappo o con corde
- Indicato per tendaggi di larghezza massima cm. 500
- Apertura tenda centrale, laterale, multipla o asimmetrica
- Il sistema è indicato per installazioni a parete, a soffitto e sotto assi di legno
- Il sistema permette di realizzare curve a 90°, centine ad ampio raggio e curve miste (solo per sistemi a strappo)
- Lo scorrimento è garantito da scivoli autolubrificanti in HDPE polietilene

### Use

- System for light or middle draped curtains
- Hand or cord operation
- Suitable for curtains up to cm 500 width
- Opening can be: central, lateral, multiple or asymmetrical
- Suitable for a wall/ceiling mounting or to be installed under wooden boards
- The cord sliding system in independent channels allows to realize 90° curves, big radius curves or mixed curves (for hand operation only)
- Sliding is guaranteed by self-lubricating sliders in polyethylene HDPE

### Utilisations

- Système pour rideaux courbés moyens et légers.
- Les rideaux enroulés ou avec des plis sont les plus répandus parce qu'ils conviennent à tous les contextes : classique, moderne, pays ou ethnique. La chose importante est de choisir les meilleurs tissus et couleurs pour votre maison, combiné avec des accessoires, le soutien et le curling le mieux adapté à votre style de meubles.
- La caractéristique de ce système est la petite taille qui lui permet d'être placé sous des haches ou des cadres.
- Le glissement est garanti par des toboggans autolubrifiants dans le HDPE
- Le système est conçu pour les installations au plafond et au mur.

### Caratteristiche tecniche

- Profilo in lega d'alluminio estrusa 6060 T5 UNI EN 755-9
- Dimensioni mm. 10x15
- Canale di scorrimento mm. 6
- Raggio di curvatura (solo per sistemi a strappo):
  - ◆ r = cm. 12 per curva a 90°
  - ◆ r = cm. 50 per curva ad ampio raggio
- Colori disponibili:
  - ◆ verniciatura a polvere a base di resine poliesteri omologata a marchio QUALICOAT BIANCO RAL 9010
- Carrucole in acetalica con perni in acciaio
- Sormonto in acetalica da cm. 7
- Accessori in acetalica autolubrificante

### Technical features

- Profile made of extruded aluminium alloy 6060 T5 UNI EN 755-9
- Size mm. 10x15
- Sliding channel mm. 6
- Curve radius: (for hand operation only)
  - ◆ r = cm. 12 for 90° curve
  - ◆ r = cm. 50 for big radius curve
- Available colours:
  - ◆ Powder coating with polyester resins, homologated QUALICOAT white RAL 9010
- - Anodized silver
- Pulleys in acetalic resin with steel pins
- 7cm acetal resin overlap
- Accessories in self-lubricating acetal resin

### Spécifications

- Profil en alliage d'aluminium extrudé 6060 T5 UNI EN 755-9
- Taille mm. 10x15
- Canal de glissement mm. 6
- Rayon de distorsion (pour les systèmes d'actionnement manuel seulement) :
  - ◆ r est cm. 12 par courbe de 90 degrés
  - ◆ r est cm. 50 pour la courbe large-gamme
- Couleurs disponibles:
  - ◆ Poudre PAINT à base de résines de polyester approuvée par la marque QUALICOAT WHITE RAL 9010
- Carrucole en acétalc avec des goupilles en acier
- Chevauchement en acétalique par cm. 7
- Accessoires acétaliques autolubrifiants

## Colori

colours / couleurs



101 Bianco / White / Blanc

## Misure profili

profiles sizes / mesures des profils

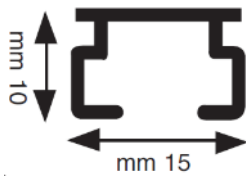

## Portata

maximum load / gamme

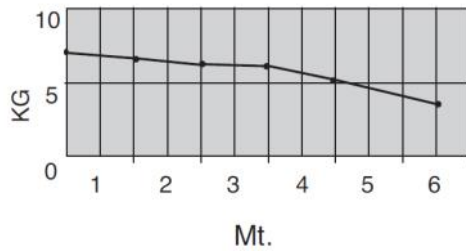

## Scivoli e scorrevoli

sliders / glisseur

Art. 3141



Art. 3146



Art. 2624



Art. 3220- 3223



## Soluzioni di utilizzo

Application solutions / Solutions d'emploi

D

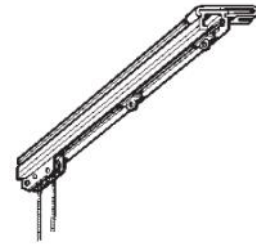

P

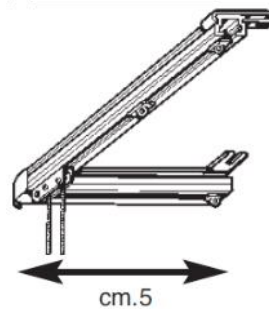

C

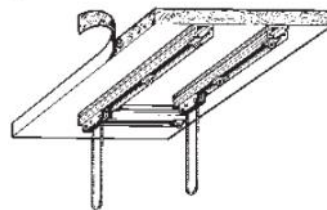
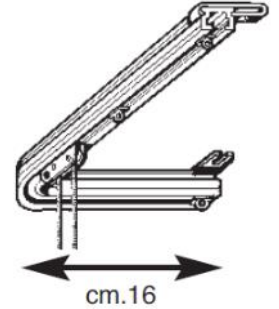

CN-I

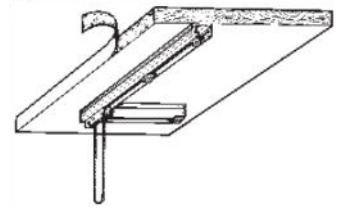

CN-E

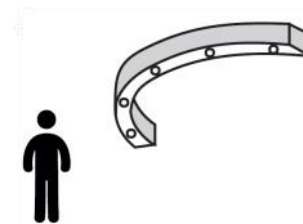

CN-IE

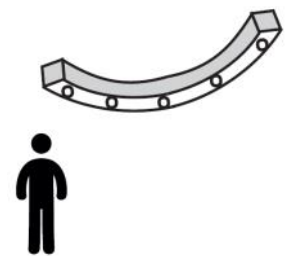

CN-A

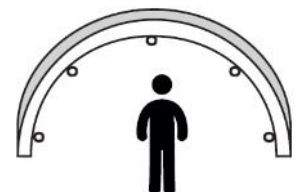
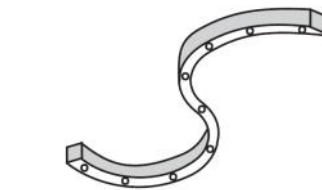

**Installazioni**  
fixing / installations

Installazione a soffitto / ceiling fixing / au plafond

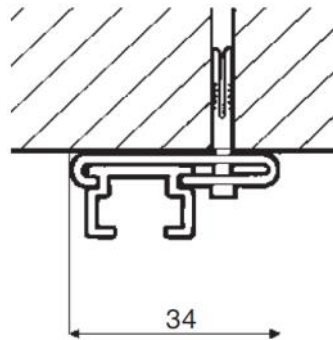

Art. 2686

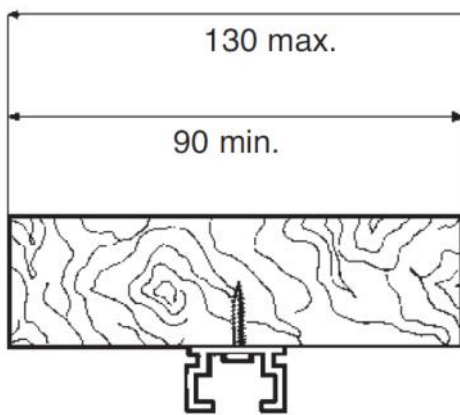

Art. 2688

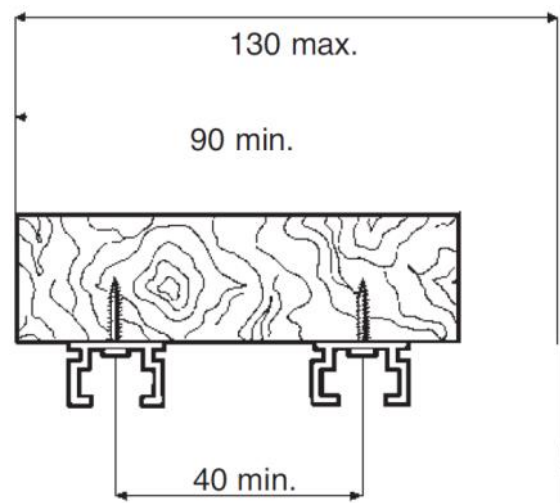

Art. 2688

Installazione a parete / wall fixing / au mur

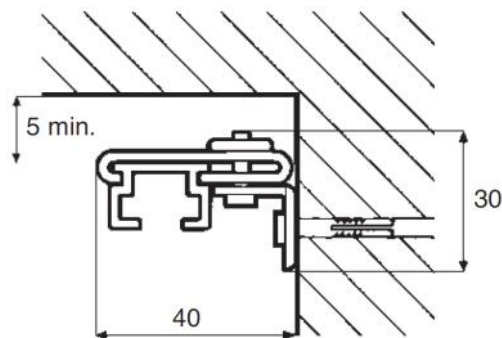

Art.2686+2687

**Esploso**

exploded view / vue éclatée

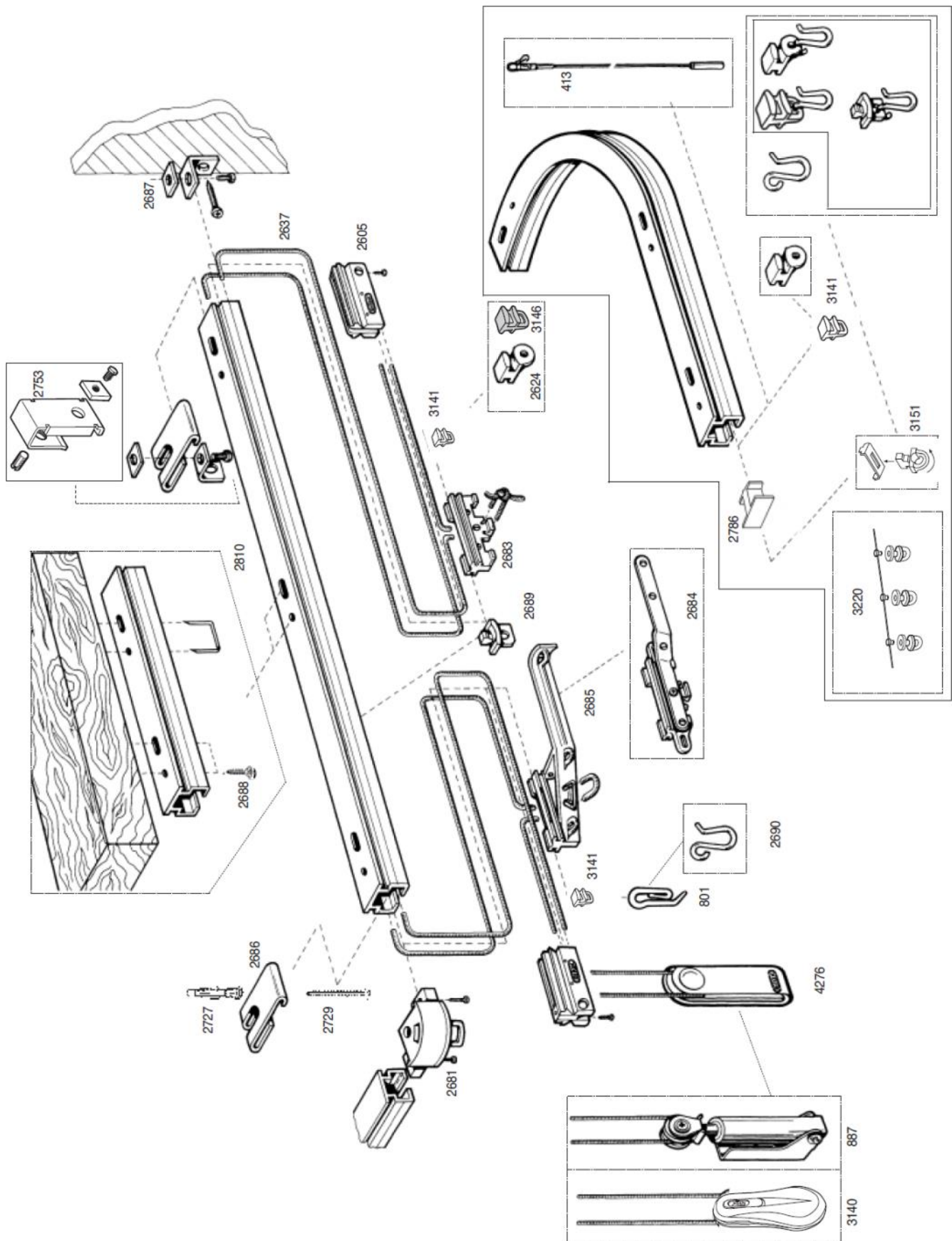



TENDE INTERNE ED ESTERNE

**Rilox Italia Srl** - Cap. Soc. €150.000,00 I./V.

Via Cascina Borniola, 15/A - 10036 Settimo Torinese (TO) - ITALY  
Reg. Imprese Torino - C.F. - P. IVA - 10634150014 - R.E.A. 1149982  
Ufficio Registro TORINO 2 - PEC: riloxitalia@pec.it  
Tel:(+39) 011 262 5473 - Fax: (+39) 011 22 22 250

[www.riloxitalia.it](http://www.riloxitalia.it)



@rilox.italia



#riloxitalia