

Hi-Tech system
EURO 2880B



Sistema per tende arricciate a corde guidate. L'EURO 2880 è un sistema per tende interamente progettato e prodotto dalla RILOX. Versione con bande laterali per "finire" al meglio la Vostra tenda.

Le tende arricciate possono essere realizzate in qualsiasi tipo di tessuto, non vi sono limitazioni né di peso né di tipologia, pertanto le possibilità d'arredo e creative risultano essere illimitate.

Le tende arricciate o con pieghe sono le più diffuse perchè adatte a tutti i contesti: classico, moderno, country o etnico. L'importante è scegliere i tessuti ed i colori migliori per la propria casa, uniti agli accessori, al sostegno e all'arricciatura più adatti al proprio stile di arredamento.



System with guided cords for draped curtains. EURO 2880 is a curtain system entirely designed and produced by RILOX. Possibility of hanging side curtains for a better finishing.

Draped curtains can be realized with any type of fabric, no weight or type limit, decoration possibilities are therefore unlimited.

Draped or pleated curtains are the most popular because they are suitable for any context: classic, modern, country or ethnic. What matters is that you choose fabrics and colours, together with accessories and curtain systems, the most appropriate to your home.



Système pour rideaux drapés avec des cordes guidées.

L'EURO 2880 est un système de rideaux entièrement conçu et fabriqué par RILOX. Les rideaux froncés peuvent être confectionnés dans n'importe quel type de tissu. Il n'y a pas de limite de poids ni de type. Les possibilités d'aménagement et de création semblent donc illimitées.

Les rideaux drapés ou plissés sont les plus courants car ils conviennent à tous les contextes: classique, moderne, national ou ethnique. L'important est de choisir les meilleurs tissus et couleurs pour votre maison, associés aux accessoires, au support et au curling qui conviennent le mieux à votre style de décoration.

SISTEMA PER TENDE ARRICCIATE CON CALATE

System for draped curtains with sides

Système à cordon avec descendente

Utilizzo

- Sistema per tende arricciate con calate
- Azionamento a corde
- Indicato per tendaggi di larghezza massima cm. 400
- Apertura tenda centrale, laterale, multipla o asimmetrica
- Il sistema è indicato per installazioni sia a soffitto sia a parete
- Il sistema di scorrimento delle corde d'azionamento in canali indipendenti permette di realizzare curve a 90°, centine ad ampio raggio, curve miste (ved. Soluzioni di utilizzo)
- Lo scorrimento è garantito da scivoli autolubrificanti in HDPE polietilene oppure da scorrevoli con rotelle

Use

- System for draped curtains and side curtains
- Cord operation
- Suitable for curtains up to cm 400 width
- Opening can be: central, lateral, multiple or asymmetrical
- It can be fixed both at the ceiling or at the wall
- The cord sliding system in independent channels allows to realize 90° curves, big radius curves or mixed curves.
- Sliding is guaranteed by self-lubricating sliders in polyethylene HDPE, or by roller sliders.

Utilisations

- Système pour rideaux courbés avec abaissé
- Entraînement à cordes
- Convient pour rideaux de largeur maximale cm. 400
- Ouverture centrale, latérale, multiple ou asymétrique du rideau
- Le système convient aussi bien pour installations au plafond et au mur
- Le système de glissement de chaîne d'entraînement dans les canaux indépendants vous permet de faire des courbes à 90 degrés, large-gamme, courbes mixtes
- La glissade est garantie par des toboggans autolubrifiants en polyéthylène HDPE ou en glissant avec des roues

Caratteristiche tecniche

- Profilo in lega d'alluminio estrusa 6060 T5 UNI EN 755-9
- Dimensioni mm. 17x26
- Canale di scorrimento mm. 6
- Raggio di curvatura:
 - ◆ r = cm. 12 per curva a 90°
 - ◆ r = cm. 50 per curva ad ampio raggio
- Colori disponibili:
 - ◆ verniciatura a polvere a base di resine poliesteri omologata a marchio QUALICOAT BIANCO RAL 9010
- Carrucole in acciaio con ruote in acetalica su perni in acciaio
- Sormonto in acetalica da cm. 7
- Accessori in acetalica autolubrificante
- Portatelo in lega d'alluminio estrusa 6060 T5 UNI EN 755-9 con Velcro adesivo (bloccato su tutta la lunghezza)

Technical features

- Profile made of extruded aluminium alloy 6060 T5 UNI EN 755-9
- Size mm. 17x26
- Sliding channel mm. 6
- Curve radius:
 - ◆ r = cm. 12 for 90° curve
 - ◆ r = cm. 50 for big radius curve
- Available colours:
 - ◆ Powder coating with polyester resins, homologated QUALICOAT white RAL 9010
- Steel pulleys with acetal resin roller on steel pins
- 7cm acetal resin overlap
- Accessories in self-lubricating acetal resin
- Panel holder made of extruded aluminium alloy T5 UNI EN 755-9 with adhesive Velcro (fixed all the length through)

Spécifications

- Profil en alliage d'aluminium extrudé 6060 T5 UNI EN 755-9
- Taille mm. 17x26
- Canal de glissement mm. 6
- Rayon de distorsion:
 - ◆ r = cm. 12 par courbe de 90 degrés
 - ◆ r = cm. 50 pour la courbe large-gamme
- Couleurs disponibles:
 - ◆ Poudre PAINT à base de résines de polyester approuvée par la marque QUALICOAT WHITE RAL 9010
- Carpals en acier avec roues acétates sur les pointes dans le mal
- Chevauchement en acétalique par cm. 7
- Accessoires acétaliques autolubrifiants
- Portatelo en alliage d'aluminium extrudé 6060 T5 UNI EN 755-9 avec adhésif Velcro (verrouillé sur toute la longueur)

Colori

colours / couleurs



101 Bianco / White / Blanc

Misure profili

profiles sizes / mesures des profils

Profilo EURO

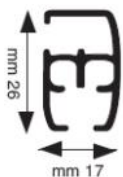

Profilo portatelo velcrato



Portata

maximum load / gamme

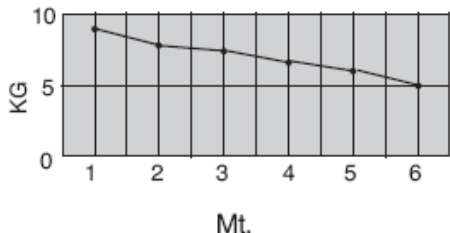

Scivoli e scorrevoli

Sliders / glisseurs

Art. 3141



Art. 3146



Art. 2624



Art.3144



Art. 3220- 3223

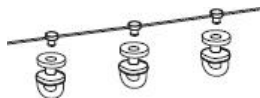

Soluzioni di utilizzo

Application solutions / Solutions d'emploi

D

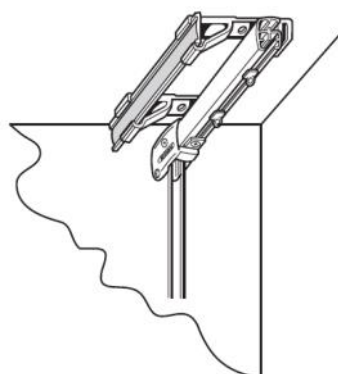

P

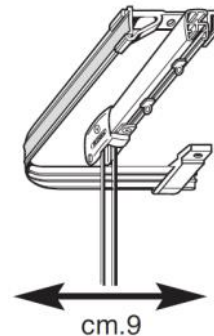

PP

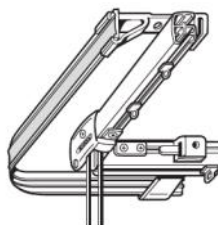

CC

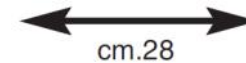
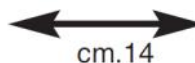
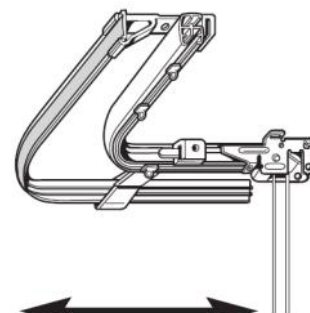

CN-I

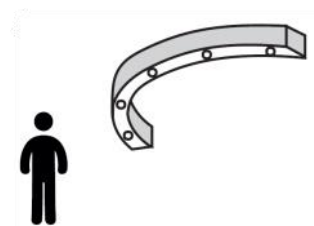

CN-E

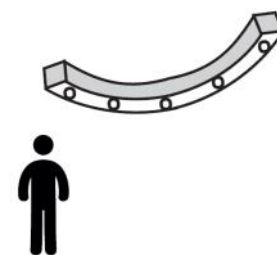

CN-IE

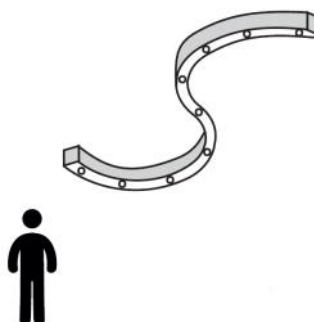

Art.3145

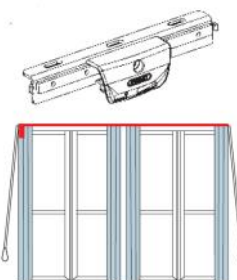

Installazioni fixing / installations

Installazione a soffitto / ceiling fixing / au plafond

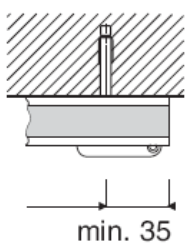

Art. 2710

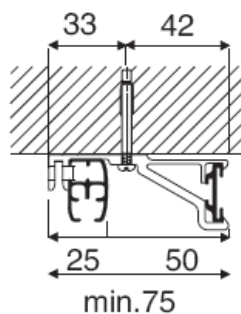

Art. 2722

Installazione a parete / wall fixing / au mur

Art. 2713+2714+2722

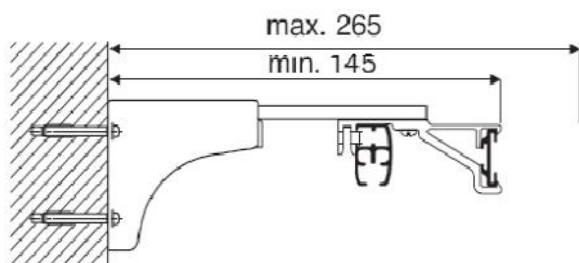

Art. 2721+2723+2725/20+2722

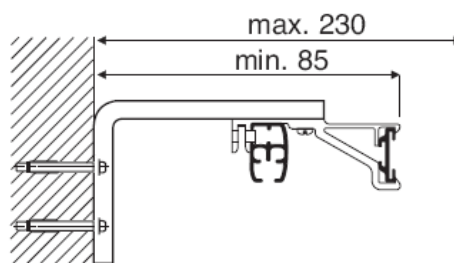

Art. 2721+2714+2725/10+2722

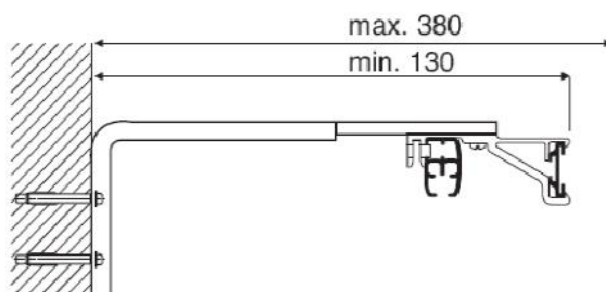

Installazione con kit saliscendi Pratico / with up-down system Pratico / avec de haut en bas kit Pratico

Soffitto / ceiling / plafond

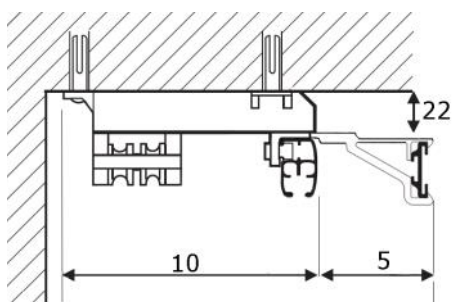

Parete / wall / mur

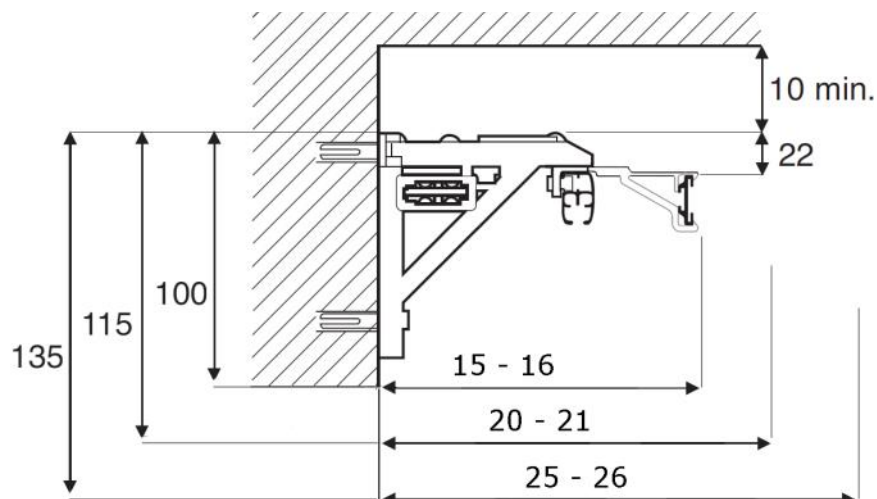

Esploso

exploded view / vue éclatée

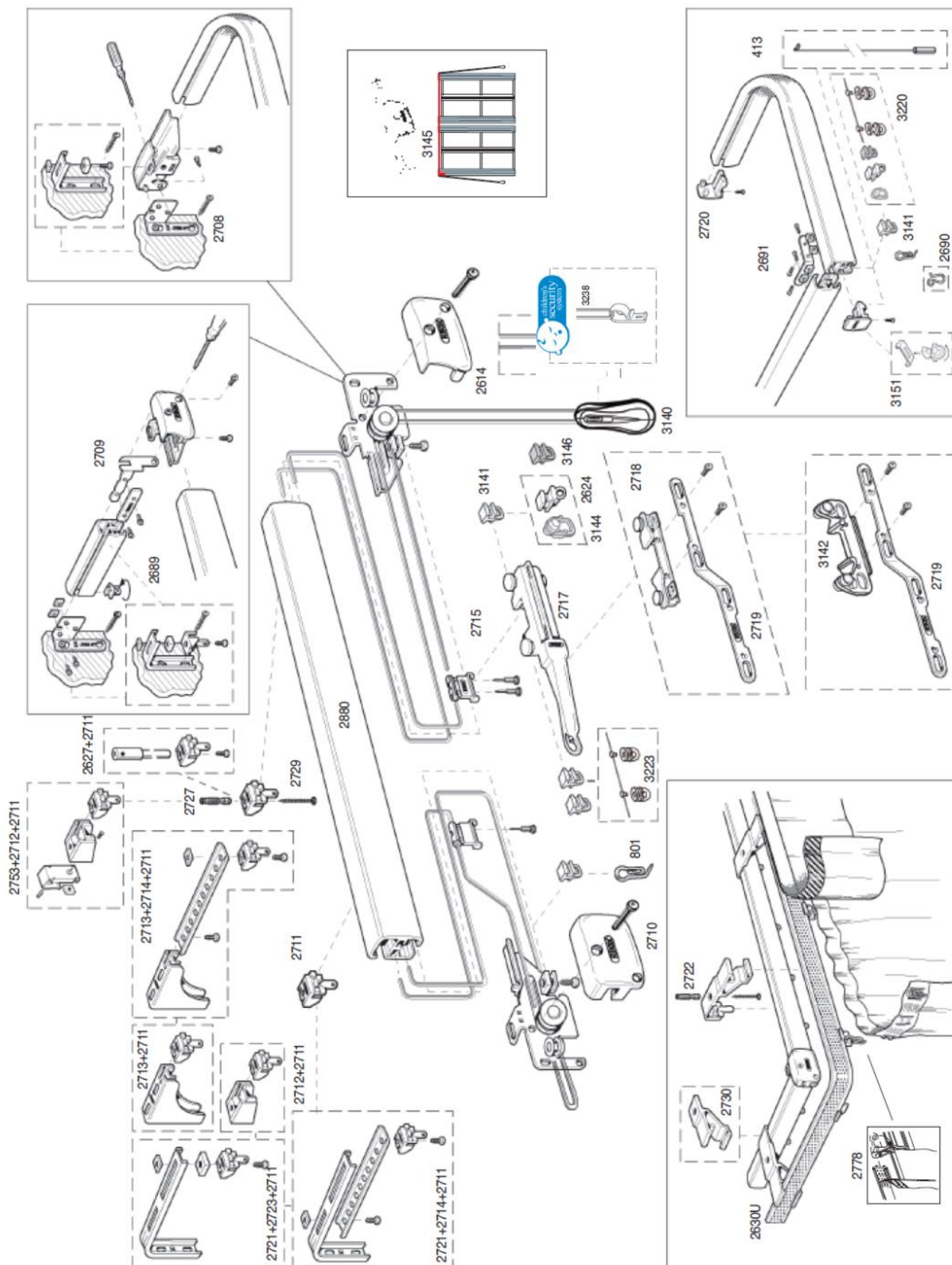



TENDE INTERNE ED ESTERNE

Rilox Italia Srl - Cap. Soc. €150.000,00 I./V.

Via Cascina Borniola, 15/A - 10036 Settimo Torinese (TO) - ITALY
Reg. Imprese Torino - C.F. - P. IVA - 10634150014 - R.E.A. 1149982
Ufficio Registro TORINO 2 - PEC: riloxitalia@pec.it
Tel:(+39) 011 262 5473 - Fax: (+39) 011 22 22 250

www.riloxitalia.it



@rilox.italia



#riloxitalia